

## Abu Dhabi Agent: Pinnacle Middle East

PlantWare has signed up with Pinnacle Middle East - PME - in Abu Dhabi as our local agent in U.A.E. for the engineering market. The picture on the right shows Mr. Sandeep Mahajan and Mr. Christian Pallesen with the signed Agency Agreement. We expect that this focus on the U.A.E will be a prosperous venture for PlantWare.



### Contact information:



Sandeep Mahajan, COO  
Email: [sandeep@pinnacleme.ae](mailto:sandeep@pinnacleme.ae)  
Cell: +971-50-8296098

## Platforms Designed for Truck Loads

### Amagerforbrænding I/S, Denmark [www.amfor.dk](http://www.amfor.dk)

PlantWare has delivered new platforms for Amagerforbrændingen as an EPC contract. The platforms are designed for load from a truck - point load at 8 tonnes. The platforms were designed to be removable, so the holes could be used as crane hoist openings. PlantWare made strength analysis of both steel and concrete structures using FEM analysis - especially for correct load distribution in the concrete.

Amagerforbrænding is the second largest waste incineration plant in Copenhagen



## FEM Analysis of turntable for service rail road

### L&H-Rørby A/S, Denmark [www.rorby.dk](http://www.rorby.dk)

PlantWare provided FEM analysis of the turntable for the service train - rail and structural steel - for the channel under the Copenhagen Harbour. The turntable has to carry the weight from the service train with a maximum load of 4.5 tonnes.

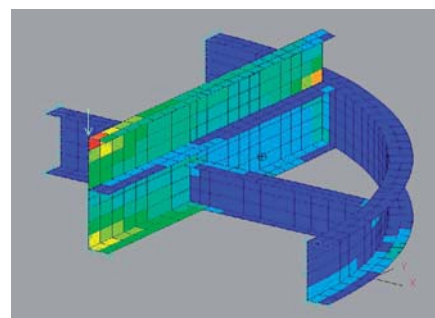

## PDMS: Air and Flue Gas Ducts

Special ducting application for design of air and flue gas ducts for e.g. power plants designed using AVEVA PDMS ([www.aveva.com](http://www.aveva.com)).

This gives an exact design as well as correct weight calculations. Furthermore, draft applications will enable automated draft generation of detailed drawings.

More information - please go to [www.plantware.dk/files/PWE-411-UK-01.pdf](http://www.plantware.dk/files/PWE-411-UK-01.pdf)

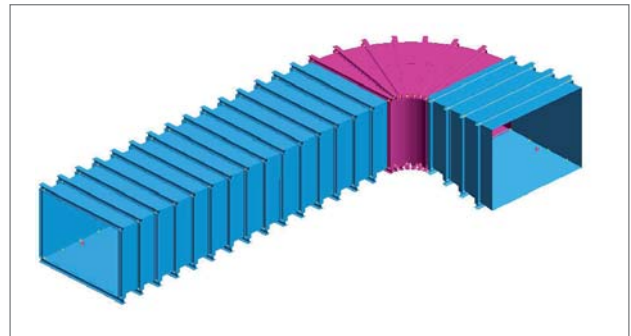

## Buffer System for Treated Water

**Gentofte Hospital, Denmark**  
[www.gentoftehospital.dk](http://www.gentoftehospital.dk)

PlantWare won an EPC order for 2 skid mounted buffer system for treated water for Gentofte Hospital - one of the major hospitals in the greater Copenhagen area. The EPC order was awarded through ALECTIA A/S as consulting engineers. The buffer skids deliver water to autoclaves and washing machines in the hospital's sterile department.

The buffer system is equipped with SIEMENS PLC and has automated sanitation routine where the temperature is raised above 85°C for reducing problems with contamination of the water.

PlantWare used Automatic Syd A/S ([www.automatic-syd.dk](http://www.automatic-syd.dk)) and L&H-Rørbyg A/S ([www.rorbyg.dk](http://www.rorbyg.dk)) as sub suppliers for electrical and mechanical supplies.

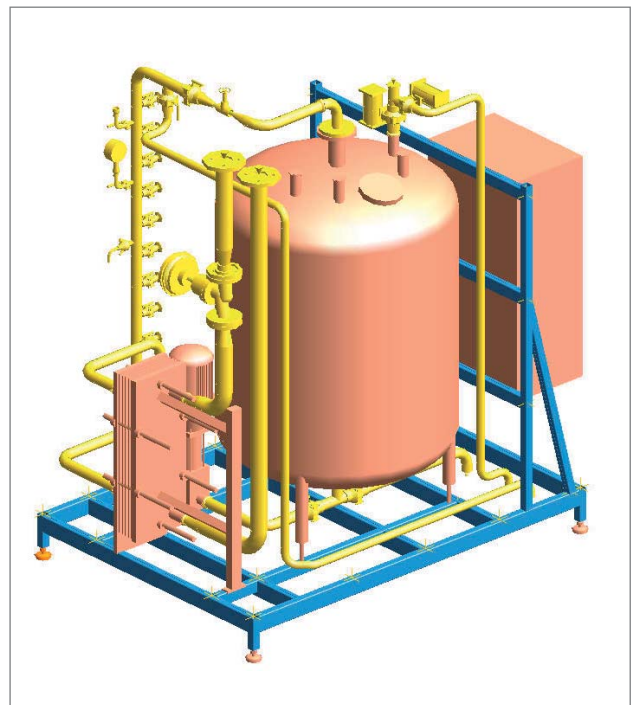

## Want to receive our e-newsletter?

If you want to receive our newsletter per e-mail - please write to [newsletter@plantware.dk](mailto:newsletter@plantware.dk) with a "YES" in the subject line and you will receive our quarterly update. If you want to cancel your subscription please mark a "NO" in the subject line instead.